

Covering Force Operations (Offense)



Don Holder, LTG, USA (ret.)



Organization

- Offensive Covering Force Doctrine
- The Armored Cavalry Regiment as an R&S force
- VII Corps in Op DESERT STORM
- Insights on Security Operations
- Discussion



Covering Force Doctrine

- Semi-independent
- Fights beyond supporting range of the main force
- Protects the main force from observation and interference
- Gives the main force time and space to act
- May become decisively engaged
- Fights for information and reports continuously



CF Characteristics

- Develops unique combat info and intelligence
- Fights outnumbered
- Needs **air parity/superiority** and **air-ground mobility advantage** over enemy units
- Relies on fast, heavy fire support
- Needs capable mobility/counter-mobility
- Hindered by anything that impedes observation or communications

Covering Force in a Corps Formation

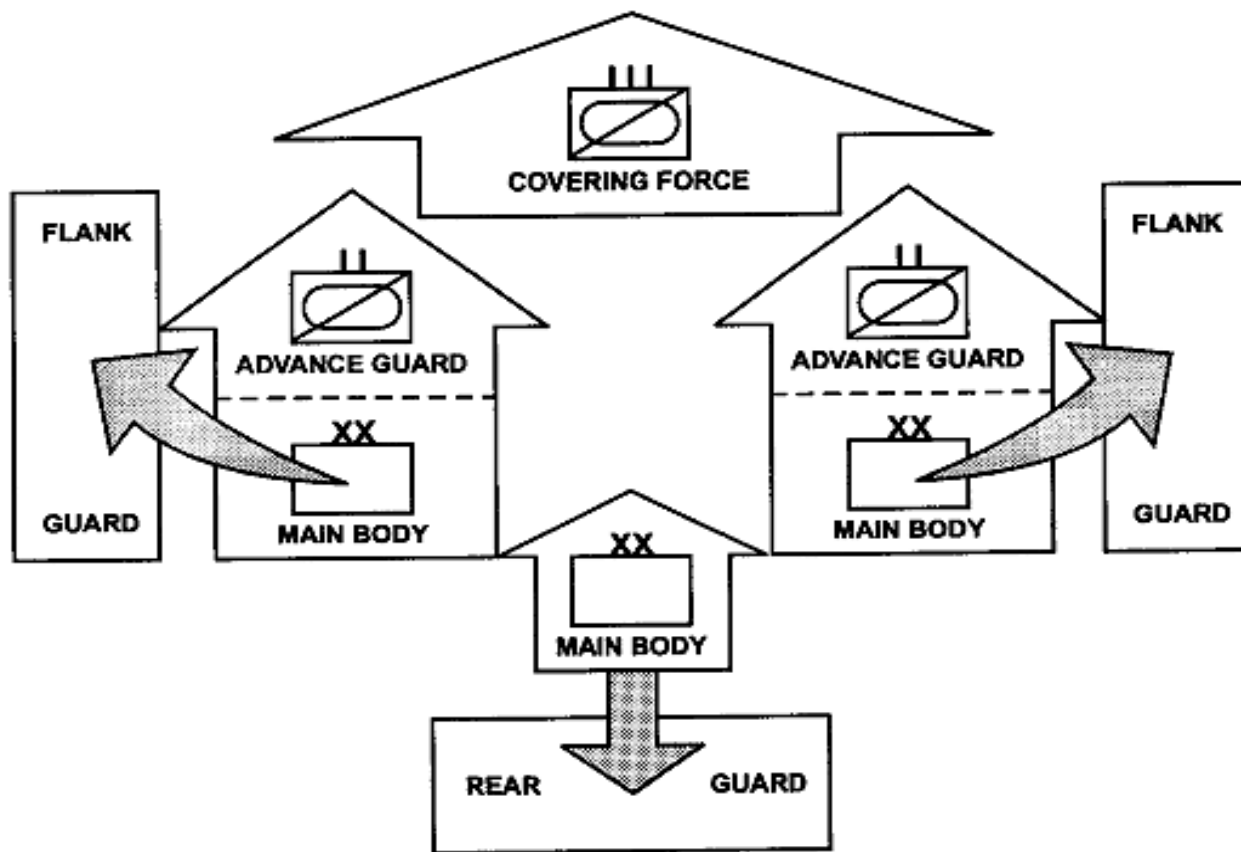
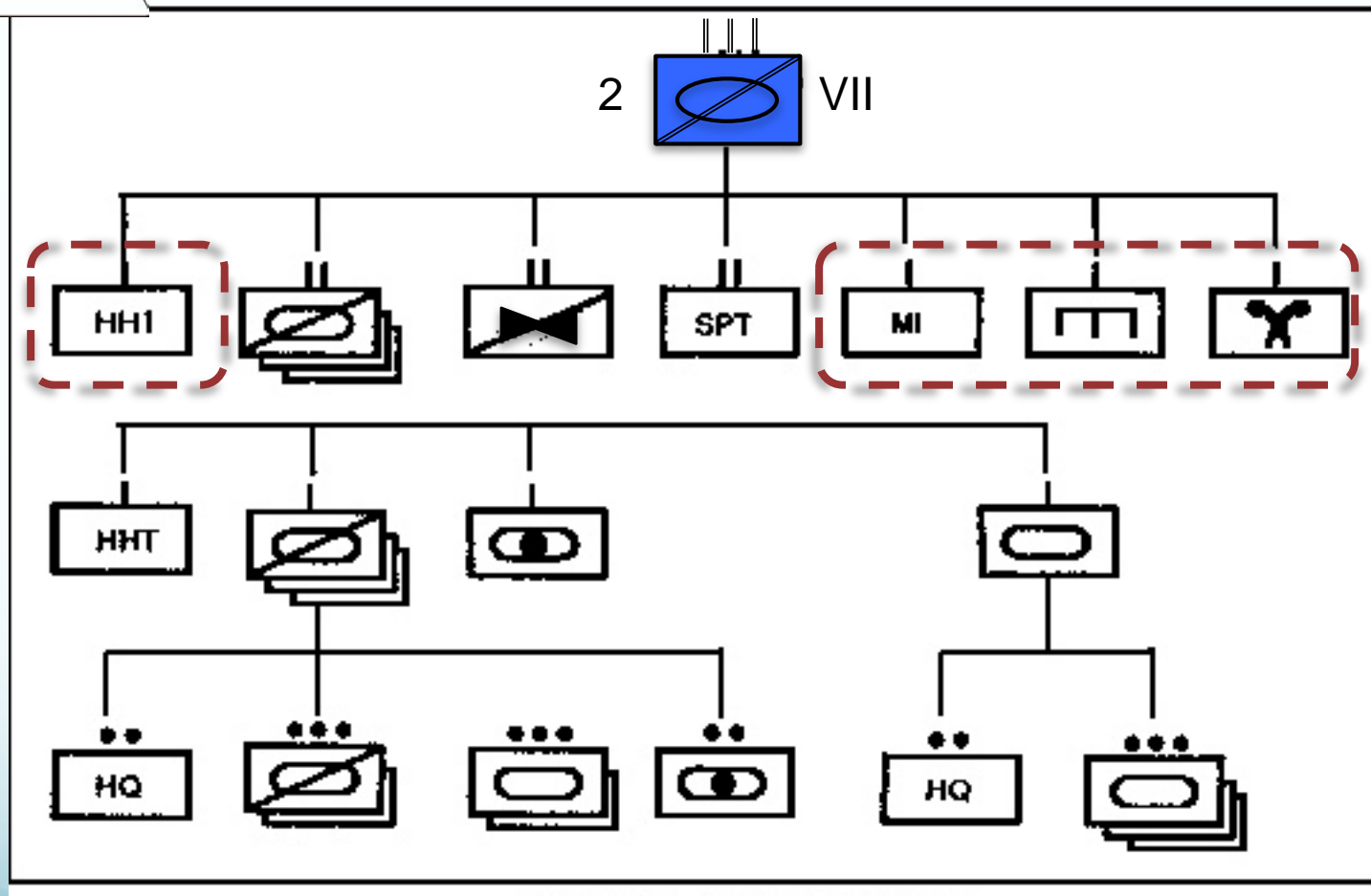

Figure 5-1. Movement to contact

The 2nd Armored Cavalry Regiment 1991



116 x Bradley Scouts, 123 x M1 Tanks, 40 x Scout Helos,
24 x AH1 Helos, 24 x 155mm SP Howitzers, c. 4,500 troops



VII Corps

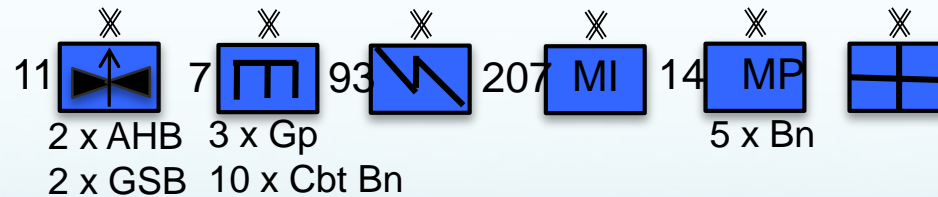
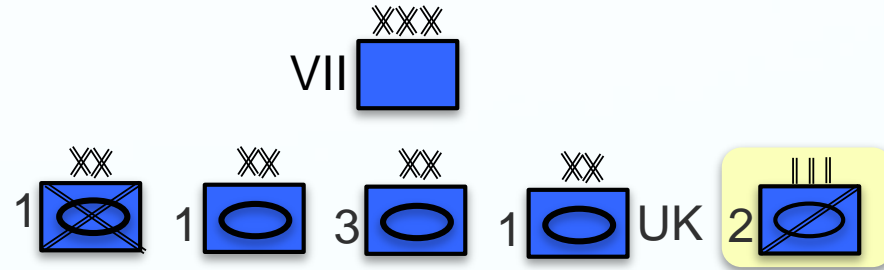

Ca. 142,000 Soldiers (AC,RC)
 5.6 M Gallons CL III/Day
 3.3 M Gallons Water/Day
 Ca. 6,000 Tons CL V/Day

2nd ACR's Combat Organization

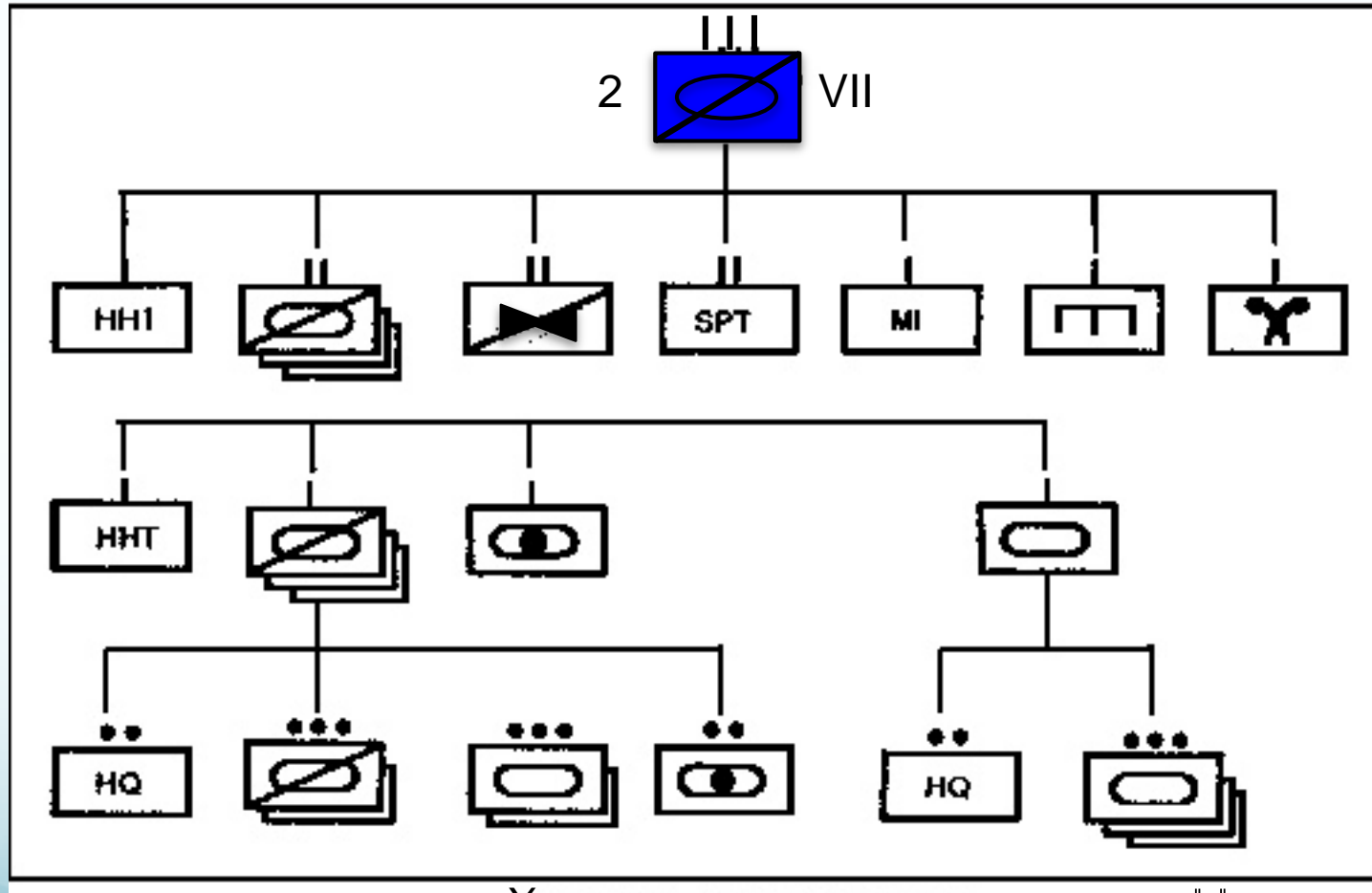

Attached: 210  2-1  82  





VII CORPS MANEUVER

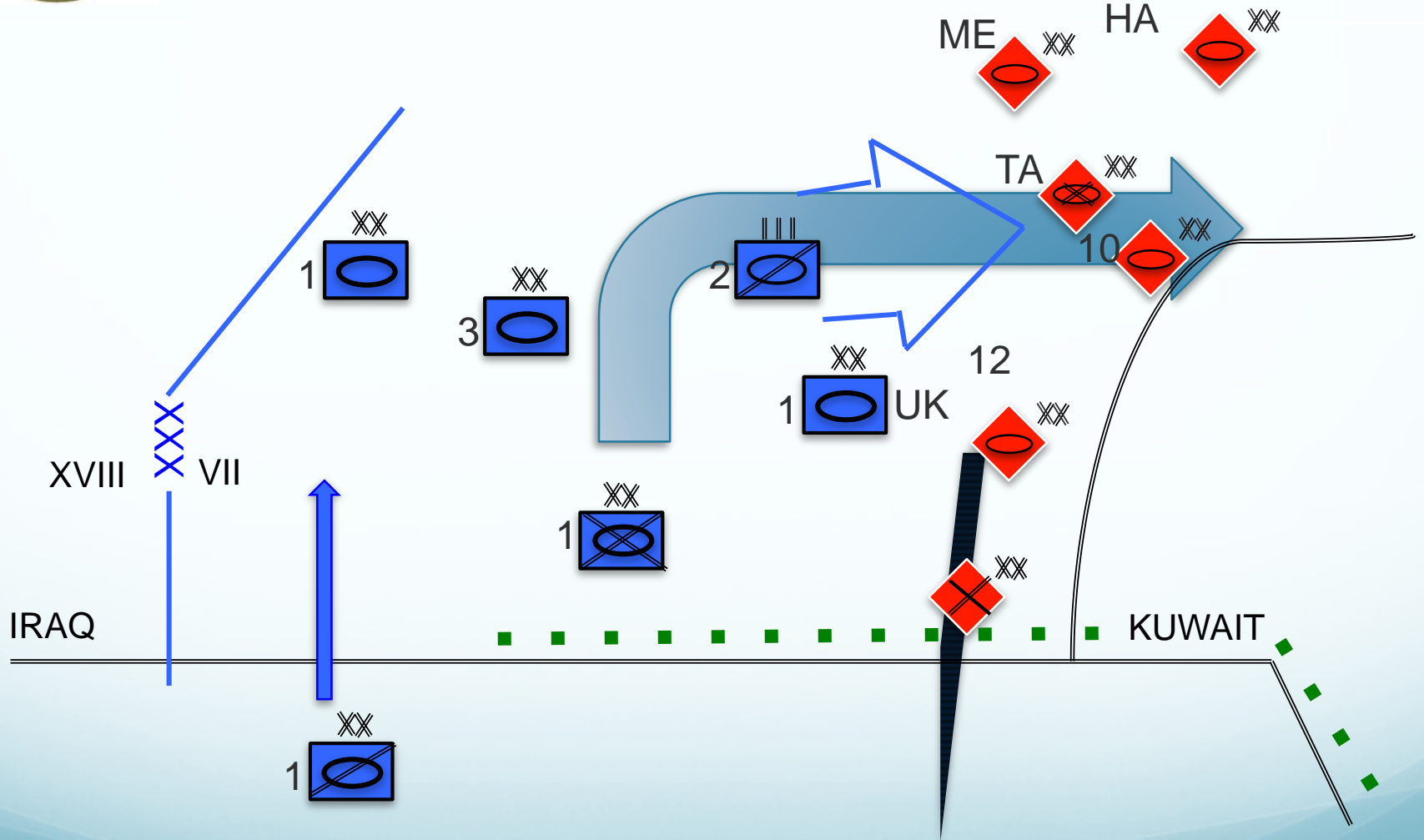

VII CORPS FRAGPLAN

26 FEB 91

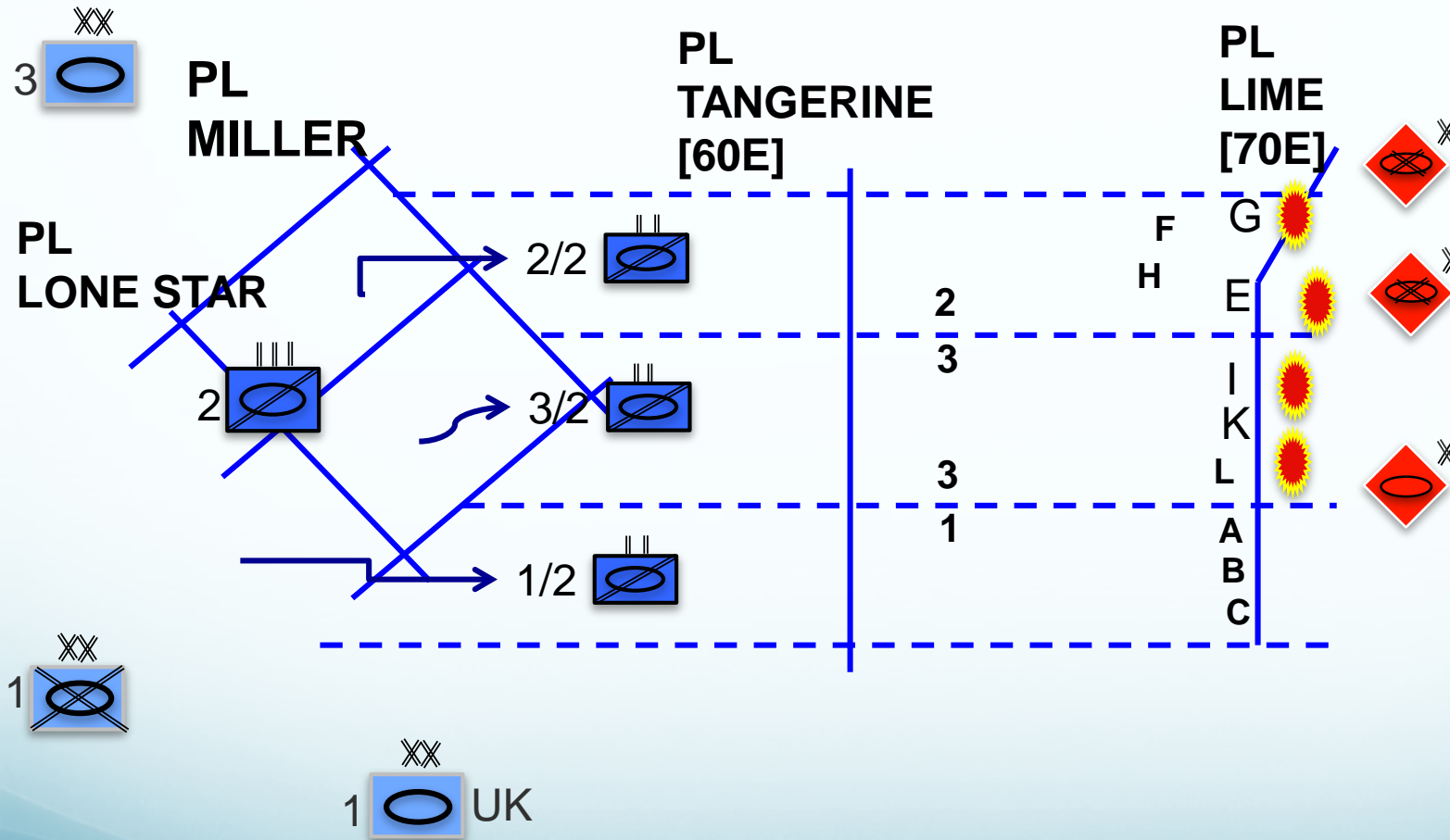

Final Move to Contact

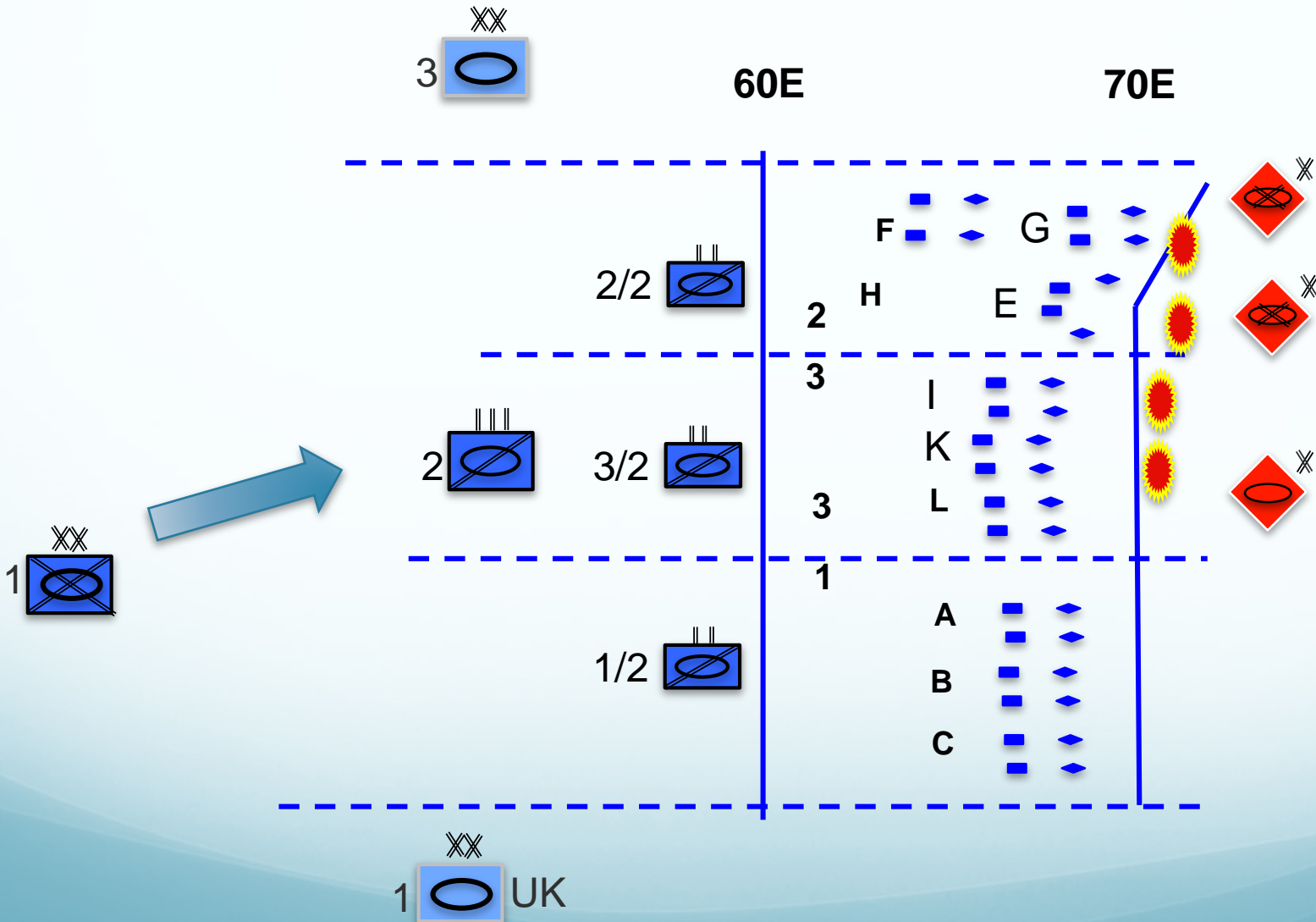



Covering Force Lessons

- Security forces shape division/corps maneuver.
- Standoff collection means and WAM /PGM alter security force use and tactics.
- **Change is nearly constant**; requires mission command, active junior leaders.
- Formation discipline can only be maintained with anticipation and active supervision.
- Momentum and tempo depend on mutual support between the main force and the covering force.
- Air-ground operations can be operationally and tactically decisive.
- Logistics will be an operation within the operation.



Other Thoughts

- Tactics should vary; not a process, no single solution
- Every level matters but capable platoons are essential
- CF maneuver should be integrated into the main fight.
- CF orients on both the main force and the enemy
- An able R&S force can be worth at least two BCTs to the formation commander
- The R&S force is 50% more capable in flying weather
- Standard TOE makes things easier, multiplies options
- CF commanders and staff often deal with opposite numbers two echelons up; good staff is combat power



Training Lessons

- Train at full scale: operate over wide, deep AOs.
- Change things continually—boundaries, objectives, direction, task org, **rates of movement**.
- Practice Passage of Lines and battle handover to main force
- Stress prompt, accurate reporting.
- Focus on formations & battle drills, platoon fire, integration of FA/mortars/CAS.
- Multi-echelon training is essential; **every leader goes to training with specific objectives and a plan**.
- Train for Mission Command and junior leader initiative. **Plan for it and critique it**.
- Make AARs tough and open

Backup Slides

Training Lessons

- Mission focus must guide training; you can't do everything equally well. **Stress combat basics, plan and execute well.**
- Apply high standards based on combat reality. Expect to fall short occasionally. Tell people how they're doing.
- Multi-echelon training is the only way to train effectively; **insist that every leader goes to training with specific objectives and a plan.**
- Formations & battle drills, platoon fire, integration of FA/mortars/CAS get you a long way.
- Train for Mission Command and junior leader initiative.
- Make AARs tough and open